

TBS-V Iced Tea Brewer FETCO Commercial Beverage Equipment



Shown with D-064 3 gallon Iced Tea Dispenser (sold separately)

Contact Information
FETCO®
Food Equipment Technologies Company
600 Rose Road
Lake Zurich • IL • 60047-1560 • USA
© 2018-2019 Food Equipment Technologies Company



fetco.com

Internet: www.fetco.com
Phone: (800) 338-2699 (US & Canada)
(847) 719-3000
Fax: (847) 719-3001
Email: sales@fetco.com
techsupport@fetco.com



Table Of Contents



ROUGH-IN DRAWINGS	3	LIST OF ERROR CODES FOR TBS-V	9
INSTALLATION GUIDE	3	FOR OPERATOR SAFETY	9
START UP INSTRUCTIONS	4	REPLACEMENT PARTS LIST TBS-V.....	11
PROGRAMMING ADJUSTMENTS.....	6	TBS-V BREW BASKET PARTS LIST.....	14
CALIBRATIONS.....	7	WIRING DIAGRAM TBS V	15
TABLE OF AUTHORITIES For TBS-V Programming...	8		

Specifications Model: TBS-V simple touch iced tea brewer with automatic dilution

Description & Features:

- Easy to use settings
- Usable with three to five gallon dispensers.
- Adjustable batch sizes. Adjustable dilution volumes Ships preset for 3 gallon batch size
- User adjustable volumes are set by timer for brew, dilution delay, and dilution time
- Dual dispenser model uses brew basket position to detect & select dispenser position.
- Factory set to brew at temperature, or user adjustable to start at any temperature (between 170°F-207°F)

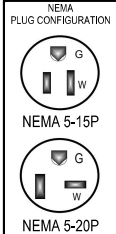
Electrical Configurations

Configuration Code		Voltage	Heater	kW	Amps	Electrical Connection	
SKU No.	Dispenser						
T002111	SINGLE	100-120 Volts	120V/1680W	1.1–1.68	11-14	NEMA 5-15P plug	
T002112	SINGLE	100-120 Volts	120V/1680W	1.1–1.68	11-14	NEMA 5-20P plug 	
T002121	DUAL	100-120 Volts	120V/1680W	1.1–1.68	11-14	NEMA 5-15P plug	
T002122	DUAL	100-120 Volts	120V/1680W	1.1–1.68	11-14	NEMA 5-20P plug 	

NOTE: Cord and plug are factory installed  denotes plug acceptable for Canada

Weights and Capacities

Height	Width	Depth	Water tank capacity	Empty Weight	Filled Weight	Shipping Weight	Shipping Dimensions
19 in 483mm	7 5/8 in 194 mm	19 in 470 mm	1.6 gallon 6.0 L	33 lb. 15 kg	46 lb. 20.8 kg	57 lb 25.9 kg	24" x 15" x 38" 591 x 268 X 943mm

Brew Capacity	8 brews per hour [3 gallon brew @1 gallon concentrate/2 gallon dilution]
Coffee Filter	15" X 5 1/2" – Standard FETCO # F001
Flow Rate	1 1/2 gallon per minute, cold water supply only
Water Supply Pressure	Unit is factory calibrated to a non-fluctuating water supply at 45 psi
Hardness	Optimal water hardness between 125-250TDS
Water Connection	3/8" Tube Y connector NOTE! Important → please connect both fill and dilution valve inlets
Total Brew Cycle	5 minutes, +35 seconds

CONTROLS	DEFAULT VALUE	RANGE
Total Brew Time	5 min:35sec	To be set by user from the ranges shown below
Hot Brew Time	215sec (1 gal.)	0-325 sec
Dilution Delay	30sec	0-500 sec
Dilution	110sec (2 gal.)	0-220 sec
		! NOTE: Volumes are controlled by timer
Tank Temperature	200°F / 93° C	170°F –207°F / 77° C – 97° C (User adjustable) (2° F/1° C Hysteresis)
Units	F° (Fahrenheit)	C° Celsius/ F° Fahrenheit

See pages 6-7 for how to adjust controls for temperature, brew volume, units - and all other settings

Rough-in Drawings

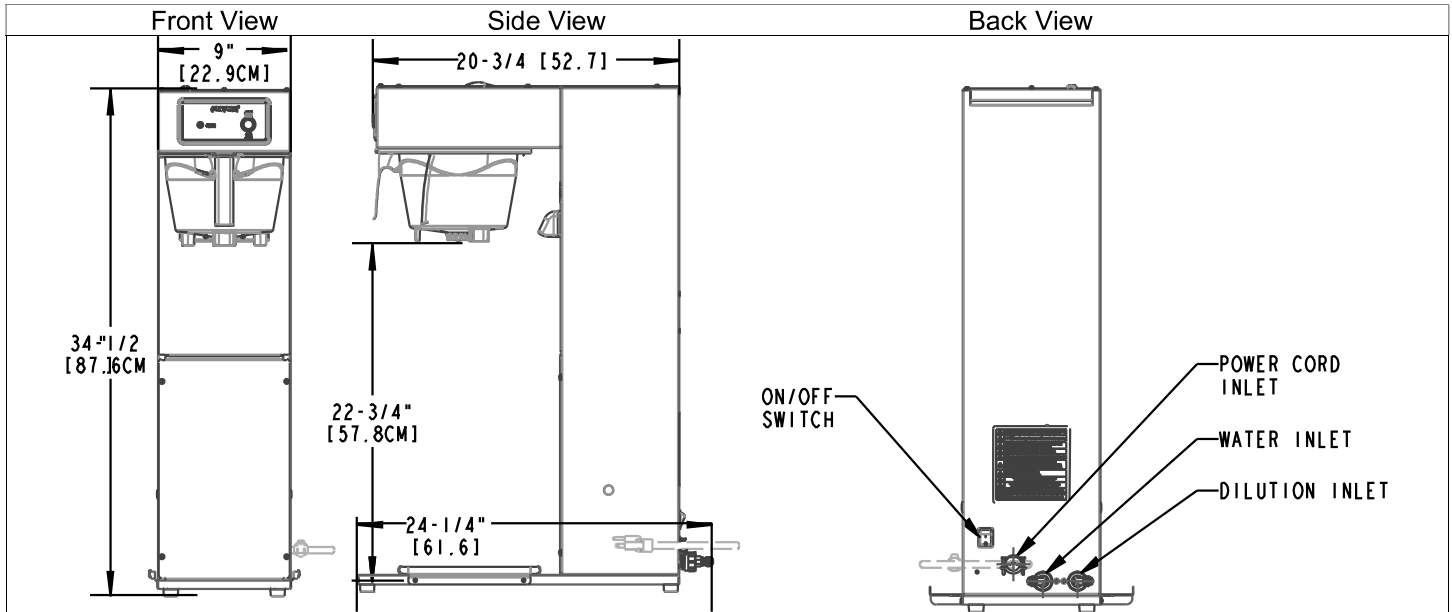

Installation Guide

(For Qualified Service Technicians Only)

General:

1. If not installed correctly by qualified personnel, the brewer will not operate properly, and damage may result
 2. Utilize only qualified beverage equipment service technicians for service and installation.
 3. Always have an empty dispenser under spray head of all brewing equipment-including when at idle
 4. Damages resulting from improper installation are not covered by the warranty and will void the warranty.
- Below are the key points to consider before installation:

Electrical:

1. All CBS—Series brewers require **an electrical ground**. Installation without grounding is dangerous.
2. Verify electrical outlets, voltages, circuits, and circuit breaker access before attaching equipment.
3. Plug the unit into the appropriate 15 or 20 amp circuit. Use a dedicated circuit for brewing equipment.
4. An electrical diagram is located in the User's Guide and online at www.fetco.com.
5. The installation must comply with applicable federal, state, and local codes having jurisdiction at your location. Check with your local inspectors to determine what codes will apply.

Plumbing:

1. This unit has **two water connections**, each must be connected to the water supply.
One connection is the water inlet for brew, the other is for dilution. Both must be plumbed.
2. North America: All installations must comply with applicable federal, state, or local plumbing codes
3. All Others: The water and waste piping and connections shall comply with the International Plumbing Code 2003, International Code Council (ICC), or to the Uniform Plumbing Code 2003 (IAPMO).
4. Use an inline water filter for all beverage equipment.
5. Install the filter unit after a water shutoff valve and in a position to facilitate filter replacement.
6. The water line and newly installed filter cartage must be flushed thoroughly prior to connecting it to the brewer to prevent debris from contaminating the machine.
7. Verify that the water line will provide a flow rate of at least 1½gpm/(5.7lpm) per minute and the water pressure is between 20-75 psig (138-517kPa) before making any connections.
8. Use a wrench on the factory fitting when connecting the incoming water line. This will reduce stress on the internal connections and reduce the possibility of leaks developing after the install has been completed
9. Install a backflow prevention device. Most municipalities require a recognized backflow preventer.
Usable on all hot beverage and cold beverage equipment is a WATTS® SD-2 or SD-3.
WATTS spring loaded double check valve models are accepted by most zoning authorities.
→The check valve should be as close to the water supply inlet of the beverage equipment as possible.

START UP INSTRUCTIONS

FETCO® TBS-V Iced Tea Brewer

CAUTION – This brewer must be manually filled with water before startup.

DO NOT operate this brewer until the hot water tank is filled with water

Damage to the heating element or brewer will result if started when dry.

To start up this TBS-V iced tea brewer:

1. Place brewer on a solid, level counter top, near an electrical outlet and water main.
2. Carefully level brewer. Use a bubble level and check both side-to-side & front-to-back
3. Connect both brewer inlets to water main. The “Y” connector provided accepts 3/8” tubing. Turn water “ON”
→Do not plug in the power cord at this time←.



First: Fill the new iced tea brewer with water for the one time “initial” fill

4. Insert the empty brew basket into the brew rails of the brewer.
5. Place an empty dispenser under the brew basket.
6. Plug the power cord into an electrical outlet (power switch-“OFF”!)
7. PUSH AND HOLD “START/STOP” BUTTON ON FRONT PANEL- THEN: TURN POWER SWITCH “ON”
 ...NOTE→ light ring on “START/STOP” button will rapidly flash a WHITE LED
See illustration below...

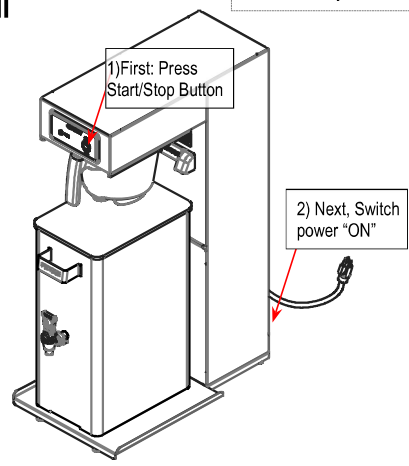

8. Press “START/STOP” button to begin initial tank fill.
 The start-up fill cycle will run for 5 minutes until time out.
 NOTE→ light ring on “START/STOP” button will glow a steady RED LED.

Tank is full when water flows from the brew basket. The excess indicates that the tank is full.

9. Press “STOP” to stop manual tank fill.
10. Recycle power by turning “OFF”, then, “ON”. Brewer will now heat and be ready to brew.

Notes:

- If water does not flow from the brew basket, the tank is not full. Water must flow out of the brew basket
- Press the “START/STOP” button again to repeat the cycle until water flows from brew basket. Next, press the “START/STOP” button to stop filling.
- Allow the brewer to heat up to full temperature. This may take up to 30 minutes.
 NOTE→ light ring on “START/STOP” button will be darkened
- When heated, the light ring on “START/STOP” button will glow with a steady WHITE LED.
- Slight dripping from the brew basket is normal as the tank heats up.
- Always leave an empty container under the brew basket

Brewer is ready when the light ring on “START/STOP” button glows with a steady WHITE LED

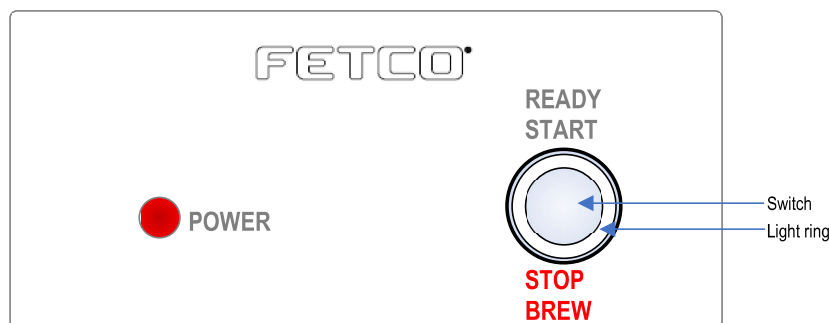

LIGHT RING DEFINITIONS

NEW BREWER	START UP
Flashing White	Start up for first fill
Steady Red	Filling for first fill (5 min.)
Steady White	Ready to brew
BREWER	IN REGULAR USE
Steady Red	Brew in progress May press “STOP” to cancel brew
Fast Red Blink	No brew basket in place
Off	Not ready to brew
Slow White Blink	READY→ with Brew at Temp “OFF” (Hot water tank temp. >170°F)

Instructions: for brew operation-fast brew

Setup is simple!

1-Connect unit to water and plug in to electrical utility

See Page 3

2-If brewer is new: see Start New Unit (on page 4) and heat

The Start button light ring will glow steady WHITE

TBS-V is "Ready To Brew" with factory set defaults

3-Add paper and loose tea to brew basket.

The Specialty Tea guidelines are 3 oz. per 3 gal. finished Iced Tea.

4- Set brew basket handle for the position of the dispenser (right/left for DUAL: center for single-follow label on basket)

5-Place clean, empty, dispenser under brew basket (D-064 Gallon Iced Tea Dispenser recommended)

6-Press start button shown below to start brew

-Note: "READY "is satisfied

Brew operation is simple. A single pushbutton-STARTS THE BREW

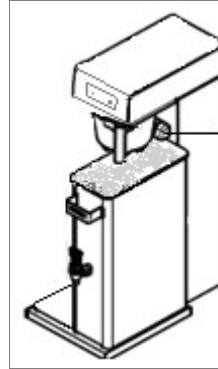

Before Starting Brew:

The brew basket has filter paper and tea. Brew basket handle is oriented to the RIGHT

←
Dilution Assembly

Clean, empty and open dispenser is under RIGHT side, and is positioned for dilution assembly. NOTE: it is very important that a dispenser is under the brew basket

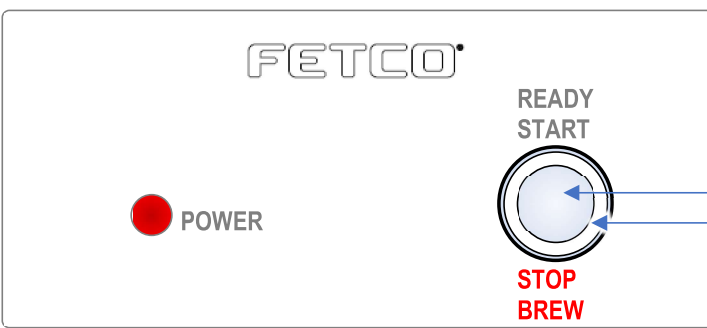

With Power ON and Brewer is filled and heated. Brewer is ready to brew when light ring glows WHITE

Add filter paper and tea

For dual model: align brew basket handle left or right side to select side to brew the batch

For single model-align to center only

Align clean-empty dispenser on brewing side

Press START Brew completes in about 6 minutes

Two position brew basket -Position of the brew basket handle left or right sets brew side (Dual model only)

Dual Model Only

Brew basket handle—LEFT

(For left hand dispenser placement)

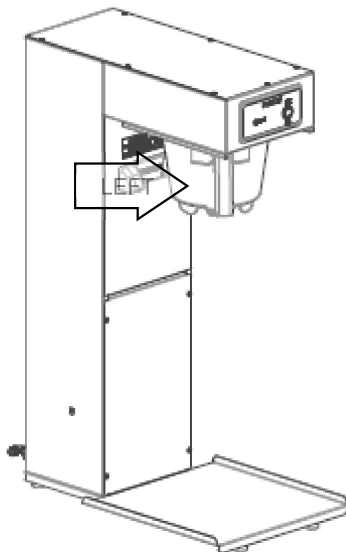

Dual Model Only

Brew basket handle— RIGHT

(For right hand dispenser placement)

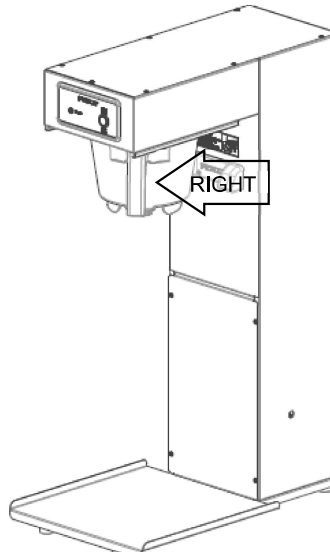

Single Model Only

Brew basket handle-CENTER

(Position dispenser in center)

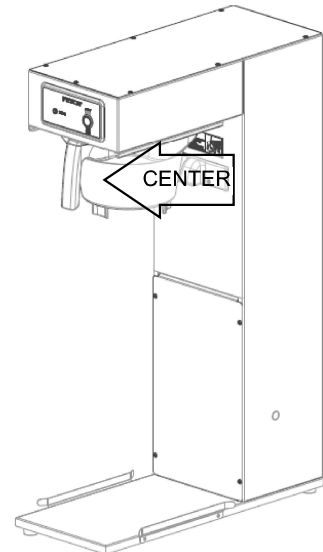

Programming Adjustments

See bottom of page 7 for how to access programming.

-Advance through the SETTINGS by pressing the START button.

-Advance through the PROGRAMMING range by pressing the black button on the control board.

-SAVE settings by holding down the START button for five seconds. Settings not SAVED will be lost on startup

SETTINGS Right & Left Side 1-3	Programming Items	Factory set Default	Programming Range [Increment]	Notes
(R&L)1 Brew Time	Seconds	215	0-325 [5 sec]	Brew volume is set by timer
(R&L)2 Dilution Time	Seconds	110	0-220 [5 sec]	Dilution volume is set by timer
(R&L)3 Dilution Delay	Seconds	30	0-500 [5 sec]	Pausing option to manually add ingredients to hot brew [cane sugar, flavoring syrup]

SET User Control Settings	Programming Items	Factory set Default	Programming Range [Increment]	Notes
C1 Tank Temp.	Degrees F (Option: Deg. C)	<u>200°F</u>	170-207 deg. (77 deg. C-97 deg.C)	See chart to correct for high altitude
C2 Brew at Temp.	Yes or No	"Yes"	Brew at tank temperature	"NO":is not recommended: may make brews inconstant
A	On/Off	OFF		Turn "ON" to enter ADVANCED

(NOTE! Enter ADVANCED Menu from the SET menu by setting the "A" icon to "ON")

ADVANCED User Control Settings	Programming Items	Factory set Default	Programming Range [Increment]	Notes
A	On/Off	OFF		Turn "ON" to enter ADVANCED
A1 Units of Meas.	Temperature	°F	°F or °C	[Switchable Units]
A2 Firmware version	Displays firmware version	0.02	May be updated	For diagnostics
A3 Restore Factory Settings	Reset to default	Completely overwrites all user settings		!THESE CHANGES TAKE EFFECT WHEN ADVANCING TO NEXT ITEM!

TO SAVE SETTINGS: 1) Press & Hold START Button 5 seconds. Display will show "STR" when saved
2) Recycle power by turning "OFF", then "ON".



A	On/Off	Turn to OFF to exit ADVANCED and return to SET menu-		
d	On/Off	OFF		Turn "ON" to enter Diagnostics

DIAGNOSTICS		Menu Item	Function
Service Settings			
d	On/Off (Toggle to "ON" to enter DIAGNOSTICS)		NOTE! DIAGNOSTICS can only be accessed from the ADVANCED menu
D1	Current tank temperature		Displays tank temperature
D2	temperature probe millivolt reading		(only for servicing)
D3	Brew Basket sensor		Indicates left or right position
D4	Heater test-activates heater for 10 seconds		(only for servicing) For safety: have tank filled)
D5	Brew Valve (fill-valve) test		Opens brew valve for full flow. Have dispenser under brew basket
D6	(Right) dilution valve test		Opens dilution valve for full flow. Have dispenser under brew basket
D7	(Left) dilution valve test		Opens left dilution valve for full flow. LEFT On DUAL model only Have dispenser under brew basket
d	On/Off	Toggle to "OFF" to exit DIAGNOSTICS and return to ADVANCED Menu	

BREW AT TEMPERATURE DEFINITONS

BREW AT TEMP: Yes

(DEFAULT: FACTORY PROGRAMMED INTO BREWER)

This allows the "BREW START" to be active only if the hot water tank is at the selected temperature. If tank temperature is below setpoint, the brewer will wait until the proper temperature is reached. The START button will be dark after brew is pressed until hot water tank is at setpoint
IMPORTANT: ALWAYS have dispenser(s) under the brew baskets when in the BREW AT TEMP mode.

BREW AT TEMP: OFF Allows brewing at any temperature above 179°F/82°C. (Not recommended)



Calibrations

- Set the volumes for the brew & dilution valves to adjust for taste, profile and for over/under potting. Brew volume and Dilution volume can be individually adjusted by user
- Set volumes and brew water temperature on the control board.
- The volumes are set by timers that control how long the brew and dilution valves are open.
- !These adjustments can expose the operator to high voltage and hot water and surfaces.!
- Unplug machine when servicing and use great care around hot surfaces.

There are two parts of the iced tea brewing cycle: BREW with HOT water and DILUTION with COLD water. The brewer default ratio is 1 to 2 . Brew is approximately 1 gallon, Dilution is approximately 2 gallons
Brew cycle is 3min.: 35sec. **shown in PROGRAMMING as 215 seconds.**
Dilution cycle is 1min:50 sec **shown in PROGRAMMING as 110 seconds.**

1) MEASURE THE FLOW RATE:

MEASURE FOR BREW VOLUME

- Place an empty 3gal dispenser under empty brew basket.
- Press START button and wait the 215 seconds [3min. 35sec.] for brew cycle to complete **Immediately** press START again to **STOP** the dilution cycle from starting
- Measure and record this volume. This is the Brew Volume. Default is 1 gallon

MEASURE FOR DILUTION VOLUME

- Empty dispenser and replace it under brew basket and press START to brew. Allow to complete
- Measure and record this volume. Default is 3 gallons. This is the total brew and dilution volume.

SUBTRACT THE TWO VOLUMES TO OBTAIN DILUTION VOLUME

- Subtract the First Brew Volume from Second Brew Volume to obtain DILUTION VOLUME
- Raise and lower flow rates as desired by setting times-in seconds in PROGRAMMING MODE

2) ADJUST THE FLOW RATES

- Using the chart on the following page: Enter programming and set up or down. Remember to SAVE by holding START button 5 seconds.

3) MEASURE THE BREW WATER TEMPERATURE

- With brewer filled- and ready to brew (light ring in start button glows with WHITE LED)
- Enter SETTINGS mode, scroll by pushing START button to C1 and press black button on control board. Board will display tank temperature on the control board

4) ADJUST THE HOT WATER TANK TEMPERATURE

- Hold down black button to scroll through the temperature range (170°F-207°F) and stop at new setting
- SAVE the new temperature setting by holding START button 5 seconds-then turn brewer OFF then ON.

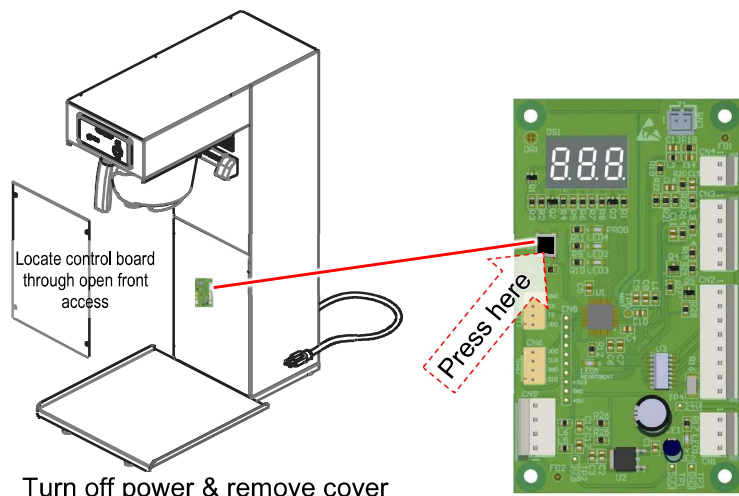

To access programming:

Turn off power Remove front access cover

- Locate control board through open front access. And Simultaneously:
- Press and hold down black (S1) button on board AND
- Toggle the power switch-to "ON"

Scroll to parameter by pressing the Start/Stop button
Advance setting by pressing Black (S1) button

Save by holding down Start/Stop button 5 seconds
LED will display STORE



Table of Authorities for TBS-V Programming

	Display	Description	Default	Min	Max	Increment
Right Batch Parameters	r-1	Brew Time (R)	215	0	325	5
	r-2	Dilution Time (R)	110	0	220	5
	r-3	Dilution Delay (R)	30	0	500	5
Left Batch Parameters	L-1	Brew Time (L)	215	0	325	5
	L-2	Dilution Time (L)	110	0	220	5
	L-3	Dilution Delay (L)	30	0	500	5
Configuration.	C-1	Tank Set Point Temperature	200	170	207	1
	C-2	Brew At Temp	Yes	No	Yes	1
	A	Advance Settings				

Advanced Settings & Diagnostics	A-1	Temperature Unit (F/C)	Deg F	Deg F	Deg C	1
	A-2	Firmware Version				
	A-3	Restore Factory Settings	No	No	Yes	1
	D	Diagnostics	Off	Off	On	1

Diagnostics	D-1	Current Tank Temperature				
	D-2	Temperature (ADC)				
	D-3	Sensors (Brew basket)				
	D-4	Heater Test (Activates Heater for 10 secs)				
	D-5	Fill Valve(Brew) Test				
	D-6	Dilution Valve Test (R)				
	D-7	Dilution Valve Test (L)				
	D-8	LED on, 7 Segment Display				
	D	Diagnostics				
D-1	Current Tank Temperature					



TBS-V Programming Specifications

FUNCTION	PARAMETER	MINIMUM	DEFAULT	MAXIMUM
BREW	SECONDS	1.0 L	3.8 L	6.5 L
DRIP DELAY	SECONDS	30 S	90 S	600 S
DILUTION	SECONDS	0.0 L	7.6 L	15.0 L
DILUTION DELAY	SECONDS	0 S	60 S	720 S
FILL/BREW TEST/CAL	PRESS AND HOLD (1 MIN FOR CAL)		TEST	
FILL/BREW FLOW RATE	RECORD F/B FLOW RATE (LPM)	0.50 (LPM)	X.XX (LPM)	2.50 (LPM)
LEFT DILUTION TEST/CAL	PRESS AND HOLD (1 MIN FOR CAL)		TEST	
LEFT DILUTION FLOW RATE	RECORD F/B FLOW RATE (LPM)	0.50 (LPM)	X.XX (LPM)	2.50 (LPM)
RIGHT DILUTION TEST/CAL	PRESS AND HOLD (1 MIN FOR CAL)		TEST	
RIGHT DILUTION FLOW RATE	RECORD F/B FLOW RATE (LPM)	0.50 (LPM)	X.XX (LPM)	2.50 (LPM)
TEMPERATURE UNITS	°F OR °C (YES/NO)		°F	
TANK TEMPERATURE	TEMPERATURE RANGE	180°F	200°F	207°F
BREW @ TEMP	YES/NO		YES	

Note: To save new settings-aways

- 1) Press & Hold START Button 5 seconds. Display will show "STR" when saved
- 2) Then recycle power by turning "OFF", then "ON".

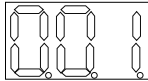
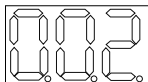
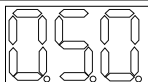
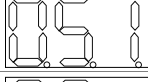
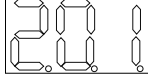
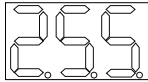
List of Error Codes for TBS-V

Flashes RED LED Start Button*	Code	7-segment control board display	Description	Possible Cause
1 Flash -then 2 sec.pause	1		Software Error : Setup corrupted	(Settings set to Factory default)
2 Flashes -then 2 sec.pause	2		Software Error : Flash checksum(CRC) error Contact Service	Unit can't recovered, need re-programming
3 Flashes -then 2 sec.pause	3	On the control board : LED4(PROG) & LED5 flash fast	Software Error : Fatal software crash	Software crash for unknown reason. Re-cycle power may help)
4 Flashes -then 2 sec.pause	50		Short in temperature probe	Short in temperature probe
5 Flashes -then 2 sec.pause	51		Open Temperature probe	Temperature 0 deg C
6 Flashes -then 2 sec.pause	201		Heater Open	Temperature change of 2.8C(5F) in 30 minutes since Heater turned ON.
7 Flashes -then 2 sec.pause	255		Keyboard (Stuck Key)	Key stuck for >20 seconds DISABLED during Initial fill : Diagnostics : D4-D8 Time extended to 2 minutes
FAST FLASH For 3 sec, then return to READY		START BUTTON flashes RED then resets to WHITE- READY Will not initiate brew when ready'	 INSERT BREW BASKET	Brew basket must be in place
*NOTE :RED LED flashes X times (depend on above error code) and then PAUSE 2 seconds				
-When READY, WHITE LED flashes slow (ON : 1s, OFF : 0.2s) -Heater error (201) is disabled during the brew -When brewing, Display solid RED (instead of blinking WHITE) to indicate brew is running and it can be stopped -Control board LED5-"heartbeat" slowly dims/brightens when normal			How to Clear Error Codes	1)CLEAR FAULT 2)Make repairs as required THEN Toggle ON/OFF switch to clear. Error codes must be cleared!

Designs, materials, specifications, physical dimensions, firmware and software protocol for equipment or replacement parts are subject to review and change by FETCO without notice

FOR OPERATOR SAFETY

This appliance is for commercial use only. Commercial cooking equipment may be unsafe for household use.

This appliance is intended for stationary indoor use. Installation and service by professional personnel only.

Brewing water is 200°F! Do not move a commercial coffee brewer once it is installed due to spillage.

Brewer is designed for brewing 3 gallons or 11 liters of finished iced tea.

WARNING-brew basket contents are hot-use care! Allow brew to complete, usually 5½ minutes.

Do not immerse the brewer in water or any other liquid.

Equipment exposed to flood and contaminated must not be used due to electrical and food safety.

Do not operate if unit has been submerged or saturated with water.

Replacement Parts Drawing TBS-V Dual and Single

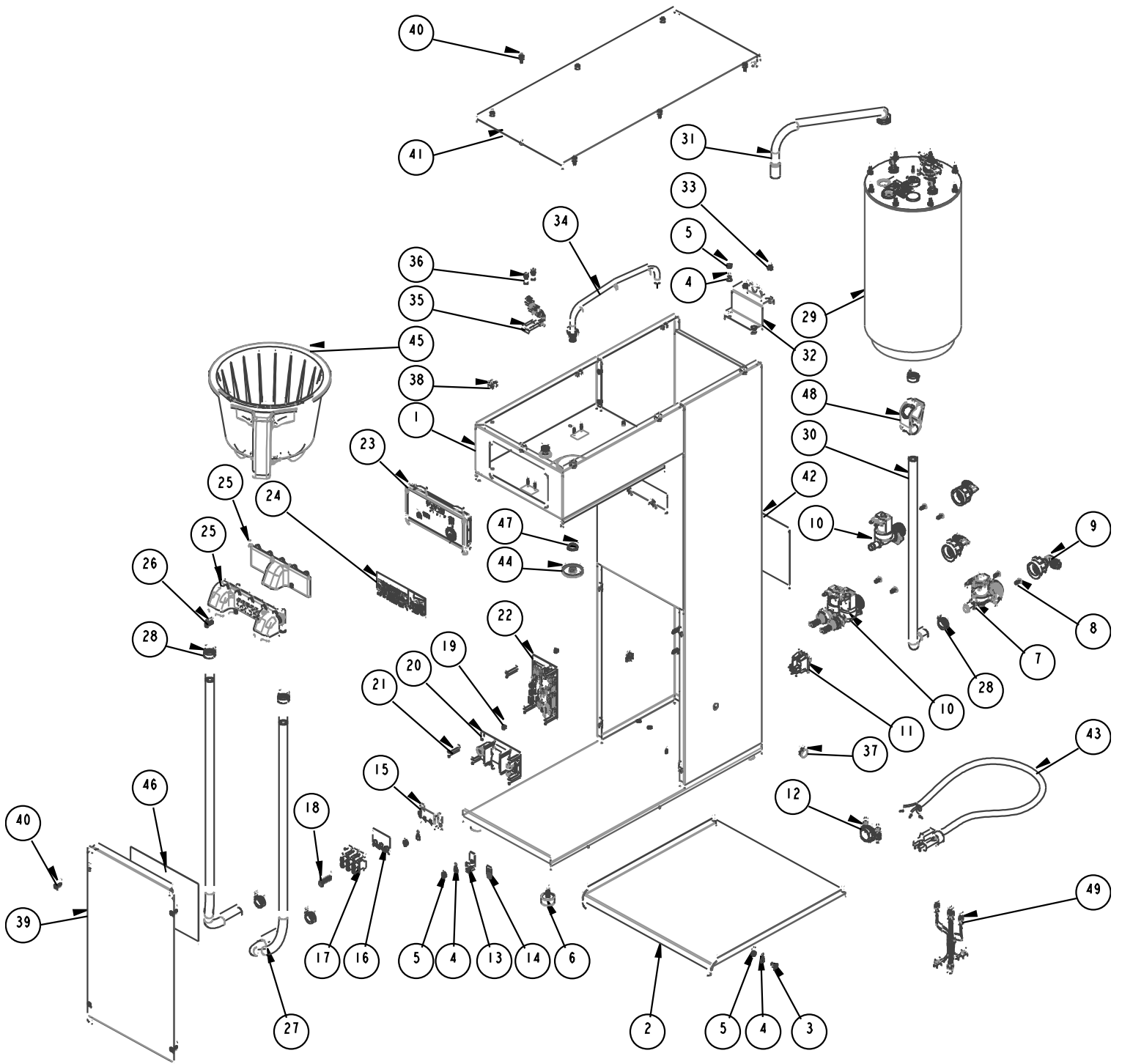

Drawing 1101.00515.00

Replacement Parts List TBS-V

REF	QTY	PART NO	DESCRIPTION	Parts List: TBS-V, 1689 W/120VAC; Drawing 1101.00515.00
1	1	1111.00092.00	WELDMENT BODY COMPLETE, TBS-V	
2	1	1112.00508.00	WELDMENT, BASE, TBS-V, DOUBLE	
3	4	1082.00023.00	SCREW, #8-32 X 3/8 TRUSS HD PHIL., MACHINE	
4	9	1083.00011.00	WASHER, #8 SCREW SIZE, INTERNAL TOOTH LOCK	
5	9	1084.00006.00	NUT, 8-32 18-8 HEX MACHINE SCREW	
6	4	1073.00021.00	FOOT, RUBBER, 1/4-20	
7	1	1057.00074.00	SOLENOID VALVE FILL VALVE SINGLE AND DUAL MODELS	
8	4	1082.00010.00	SCREW, PAN HD. PHIL. MACH., M4x10 ZINC-PLATED	
9	2	1102.00243.00	ADAPTER ASSY, 3/4" BSP x 1/4" NPT x 3/8" TUBE	
10	1	1102.00404.00	VALVE ASSEMBLY DILUTION-DUAL MODEL ONLY	
10	1	1057.00043.00	VALVE ASSEMBLY DILUTION-SINGLE MODEL ONLY	
11	1	1058.00024.00	SWITCH, POWER, DOUBLE POLE, 16A, 125/250 VAC	
12	1	1086.00008.00	CONNECTOR, CLAMP, NON-METALLIC CABLE, 3/4"	
13	1	1065.00009.00	GROUND LUG CONNECTOR, 14-2 AWG, ALUMINUM	
14	1	1044.00012.00	LABEL GROUND, CE	
15	1	1112.00246.00	WELDMENT BRACKET TERMINAL BLOCK, 3 POLE	
16	1	1052.00025.00	PLATE, MARKING #BS1016E	
17	1	1052.00022.00	EUROSTRIP HE10 TERM. BLOCK, 3 POLE, 50AMP, 18-8 AWG	
18	2	1082.00082.00	SCREW, PHILLIP HD., 8-32 THREAD	
19	8	1081.00006.00	SPACER, 6MM OD x 3.2MM ID x 5MM LG, Z/P	
20	1	1052.00001.00	POWER SUPPLY, 90-264VAC/24VDC, 1.8A	
21	8	1029.00012.00	SPACER, .25" HEX X 1" LG, FEM #4-40 THREAD	
22	1	1051.00043.00	CONTROL BOARD, TBS V	
23	1	1102.00397.00	ASSEMBLY, SWITCH PANEL, TBS-V	
24	1	1046.00031.00	LABEL, SPRAY HEAD WARNING, 1.5" X 5.0"	
25	1	1102.00196.00	ASSEMBLY, FAUCET DILUTION, DUAL MODEL ONLY	
25	1	1102.00395.00	ASSEMBLY, FAUCET DILUTION, SINGLE MODEL ONLY	
26	2	1082.00058.00	SCREW, # 8-32 X 5/8, FLAT HD, PH, 18-8 SS	
27	2	1025.00127.00	TUBE, 5/8"OD X 3/8"ID 26.00"LG	
28	6	1086.00003.00	UNICLAMP, 15.9 HOSE OD CLAMP	
29	1	1104.00157.00	TANK ASSEMBLY, TBS-V, 1370W/120VAC	
30	1	1025.00038.00	TUBE, 5/8"OD X 3/8"ID X 20"LG, DRAIN	
31	1	1024.00102.00	VENT TUBE, TBS-V	
32	1	1003.00354.00	TANK BRACKET, TBS-V	
33	2	1084.00051.00	NUT, HEX LOCKWASHER, #8-32, 18-8 ST. STL.	
34	1	1112.00519.00	WELDMENT, SPRAY CUTTER TUBE FITTING, TBS - V	
35	2	1102.00113.00	SWITCH, REED, ASSEMBLY	
36	4	1029.00006.00	NUT, FINGER KNURLED, #4-40	
37	2	1086.00047.00	CAP PLUG, PANEL, 15/32 ID x 5/8 OD, TBS-2111	
38	11	1084.00011.00	NUT, CLIP ON (J-NUT), #6-32, 22-20 GA., BLK-PH FINISH	
39	1	1001.00379.00	COVER PLATE, FRONT, TBS-V	
40	11	1082.00017.00	SCREW, TRUSS HD. PHIL. MACHINE, # 6-32 X 1/2 LG.	
41	1	1001.00384.00	COVER PLATE, TOP, TBS-V	
42	1	1046.00035.00	LABEL, WARNING "TO REDUCE RISK OF ELECTRIC SHOCK OR FIRE"	
43	1	1063.00016.00	POWER CORD, 120VAC W/NEMA 5-15P PLUG	
44	1	1005.00030.00	WELDING, DOME SPRAY CUTTER, 6 HOLES (Ø.078), TBS-V	
45	1	B013000G2	BREW BASKET ASS'Y ROUND, DUAL MODEL ONLY	
45	1	B020000G2	BREW BASKET ASS'Y SQUARE, SINGLE MODEL ONLY	
46	1	1401.00163.00	WIRING DIAGRAM, TBS-V, 120V HEATER, UL	
47	1	1084.00041.00.	HEX NUT, 7/16-20 x 1/8" THK	
48	1	1086.00009.00	CLAMP, 3/4" MAX TUBE OD FLOW CONTROL	
49	1	1402.00101.00	WIRE HARNESS, TBS-V, UL	
	1	1102.00424.00	"Y" CONNECTOR-PLUMBING INSTALLATION MANIFOLD	
	1	1085.00012.00	DESCALING SPRING	
			BOLDED Text shows TBS-V Dual/Single parts selection	

TBS-V Hot Water Tank Parts List

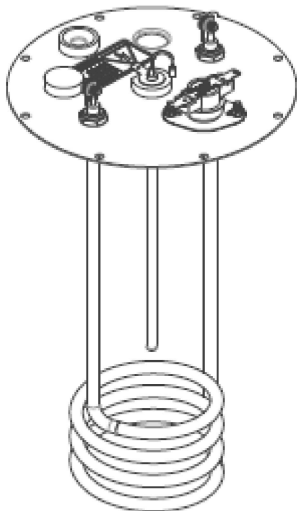

COMPLETE TANK TOP ASSY, TBS-V, 1680W/120VAC
Part Number 1102.00396.00

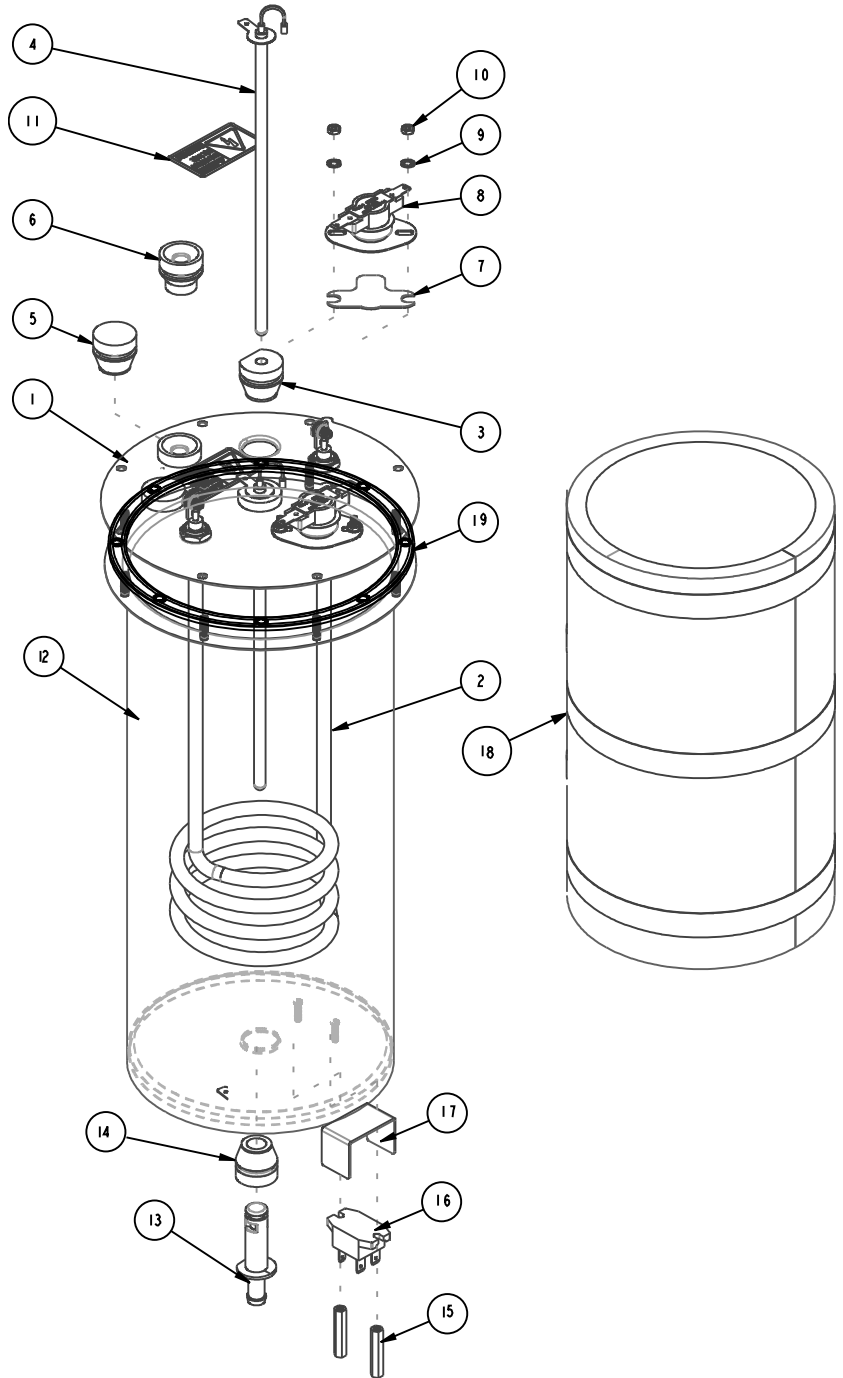

Hot Water Tank Capacity 1.6 gallon 6.0 L

OPEN	
Leave open for use	
PINCH SHUT	
To drain tank & service brewer	

Tank Drain

The water tank must be drained before maintenance procedures, and when the unit is to be relocated or shipped

1. Disconnect power to unit.
2. Move the unit near a sink or obtain a container large enough to hold four gallons of water and a hose clamp.
Note that the tank may hold 1.6 gallons and that the drain line will be clamped to empty the container.
3. Remove the tank cover and allow the tank to cool to a safe temperature
4. The tank drain is located on the back of the unit. Turn the drain plug one-quarter turn in either direction
5. Pull the plug out far enough to expose the silicone tube
6. Using pliers loosen the hose clamp and move it back over the tube.
7. Crimp the tube an inch or two away from the drain plug to prevent water from flowing.
8. Use the other hand to pull the drain plug out of the tube.
9. Release the crimped tube and allow the water to flow into the sink or container.

Replacement Parts List for TBS-V Hot Water Tank

REF	QTY	PART NO	DESCRIPTION	Hot Water Tank Parts List: TBS-V, 1689 W/120VAC
1	1	1114.00158.00	WELDMENT, TANK COVER, TBS-V	
2	1	1107.00041.00	HEATER ASS'Y., IMMERSION, 1680W/120VAC, TBS-V	
3	1	1024.00062.00	GROMMET, SHORT, SILICONE, LEVEL AND TEMP PROBE	
4	1	1102.00161.00	PROBE ASSEMBLY, TEMP. AND LLC, 8" LONG	
5	1	1024.00051.00	GROMMET, SILICONE, BLANK	
6	1	1024.00092.00	GROMMET FOR BREW TUBE, SILICONE, CBS-2121	
7	1	1003.00005.00	BRACKET, ONE SHOT THERMOSTAT	
8	1	1053.00004.00	THERMOSTAT, SINGLE SHOT, 25A	
9	2	1083.00009.00	WASHER, #6 SCREW , INTL TOOTH LOCKWASHER	
10	2	1084.00010.00	NUT, HEX, #6-32, UNDERSIZED, ZINC PLATED	
11	1	1044.00004.00	LABEL, DANGER, HIGH VOLTAGE	
12	1	1114.00156.00	WELDMENT, TANK BODY, TBS-V	
13	1	1023.00166.00	FITTING, COLD WATER INLET, GROMMET DESIGN	
14	1	1024.00050.00	GROMMET, SILICONE, 11.4mm ID	
15	2	1081.00042.00	STANDOFF, 1/4" HEX	
16	1	1052.00056.00	RELAY, SOLID STATE, PANEL MTG. EL100D5 05	
17	1	1003.00006.00	BRACKET, HEAT SINK	
18	1	1022.00110.00	INSULATION TANK TBS-V	
19	1	1024.00084.00	GASKET, HOT WATER TANK, CBS-2121	
Not Shown	8	1084.00051.00	NUT, HEX LOCKWASHER, #8-32, 18-8 ST. STL.	

Chart to correct for boiling point for altitude Tank water temperature.		
Altitude (ft.)	Suggested Setting(°F)	Boiling point (° F)
0	200	212.0
500	200	211.1
1000	200	210.2
2000	200	208.4
2500	200	207.5
3000	200	206.6
3500	197	205.7
4000	195	204.8
4500	194	203.9
5000	194	203.0
5500	193	202.0
6000	192	201.1
6500	191	200.2
7000	190	199.3
7500	188	198.3
8000	187	197.4

	WARNING To reduce the risk of electric shock or fire.
	FETCO hot beverage equipment is for commercial use only.
	Do not remove or open cover. No user serviceable parts inside. Refer installation, adjustments and service to qualified personnel.
	Warning! Disconnect from power supply before servicing. This appliance is always energized when connected to a power source.
	Locate unit away from source of heat. Do not install or use near combustibles.
	Brewer has hot surfaces. Use care when removing brew basket- Allow time for it to drain completely when brew is completed.
	Use dedicated circuit with capacity rated by local code or National Electrical Code for the current draw of this equipment. Check the serial number plate for power requirements
	Failure to comply with safety warnings risks equipment damage, property damage, fire, burns or shock hazard
	NOTICE This equipment must be installed with a backflow protection device to comply with federal, state or local municipality codes.
	NOTICE Read all instructions before installing or operating this unit Pre-fill unit before first use. Fill with pure water only.

Warning label on back of unit 1046.00049.00

LIMING

To prevent liming problems in tank fittings:

- 1) Remove spray head and clean it with any beverage service delimer or vinegar, rinse and wipe dry
- 2) Then insert deliming spring all the way into the tank.

- When inserted into tank properly, no more than ten inches of the spring should be visible at the spray head fitting. Saw back and forth five or six times. This will keep fittings open and clear of lime.
- In hard water areas this should be done every day. This process takes approximately one minute.
- In all areas the spray head should be cleaned at least once a week.

NOTE: If bad liming has already occurred, a deliming service may be required for the hot water tank

TBS-V Brew Basket Parts List

TBS-V has two brew basket types: Square type for TBS-V Single Round type for TBS-V Dual brewer

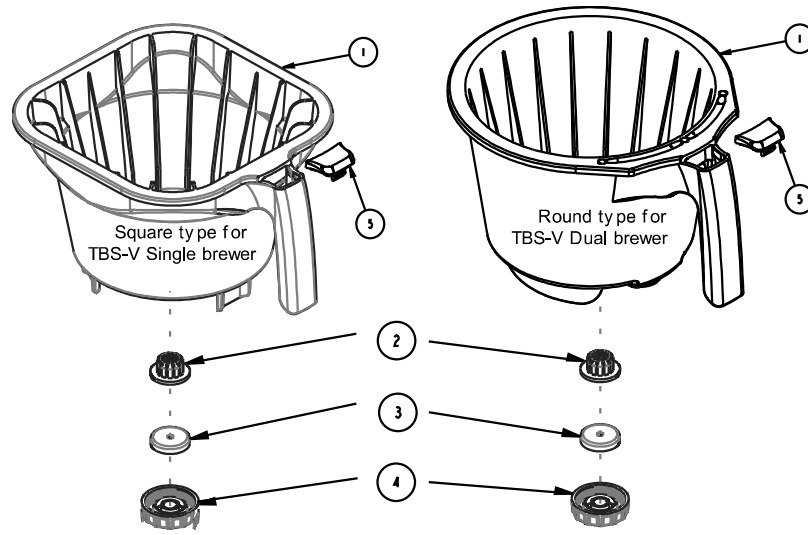

Ref#	Qty	Part Number	Description
1	1	1023.00289.00	BREW BASKET, 16" X 6" SQUARE-SINGLE BREWER ONLY
1	1	1023.00182.00	BREW BASKET, ROUND-DUAL BREWER ONLY
2	1	1024.00060.00	STRAINER, SILICONE
3*	1	1023.00185.00	ORIFICE, SET OF 7 SEE BELOW*
4	1	1023.00179.00	NUT, BREW BASKET ORIFICE HOLDER
5	1	1023.00191.00	PLUG, BB HANDLE, GREEN
NS	1	B020000G2	Complete SQUARE TBS-V Brew basket → For SINGLE brewer only
NS	1	B013000G2	Complete ROUND TBS-V Brew basket → For DUAL brewer only

* Reference #3 orifice set size

0.094	11:30 minutes: seconds
0.094 is DEFAULT-and is factory installed on brew basket	
0.062	24:30 minutes: seconds
0.078	17:30 minutes: seconds
0.086	15:30 minutes: seconds
0.104	10:30 minutes: seconds
0.125	8:10 minutes: seconds
0.280	1:20 minutes: seconds

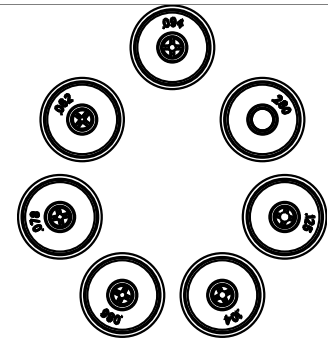

Orifice inserts for brew basket
0.094 is factory installed

Wiring Diagram TBS V

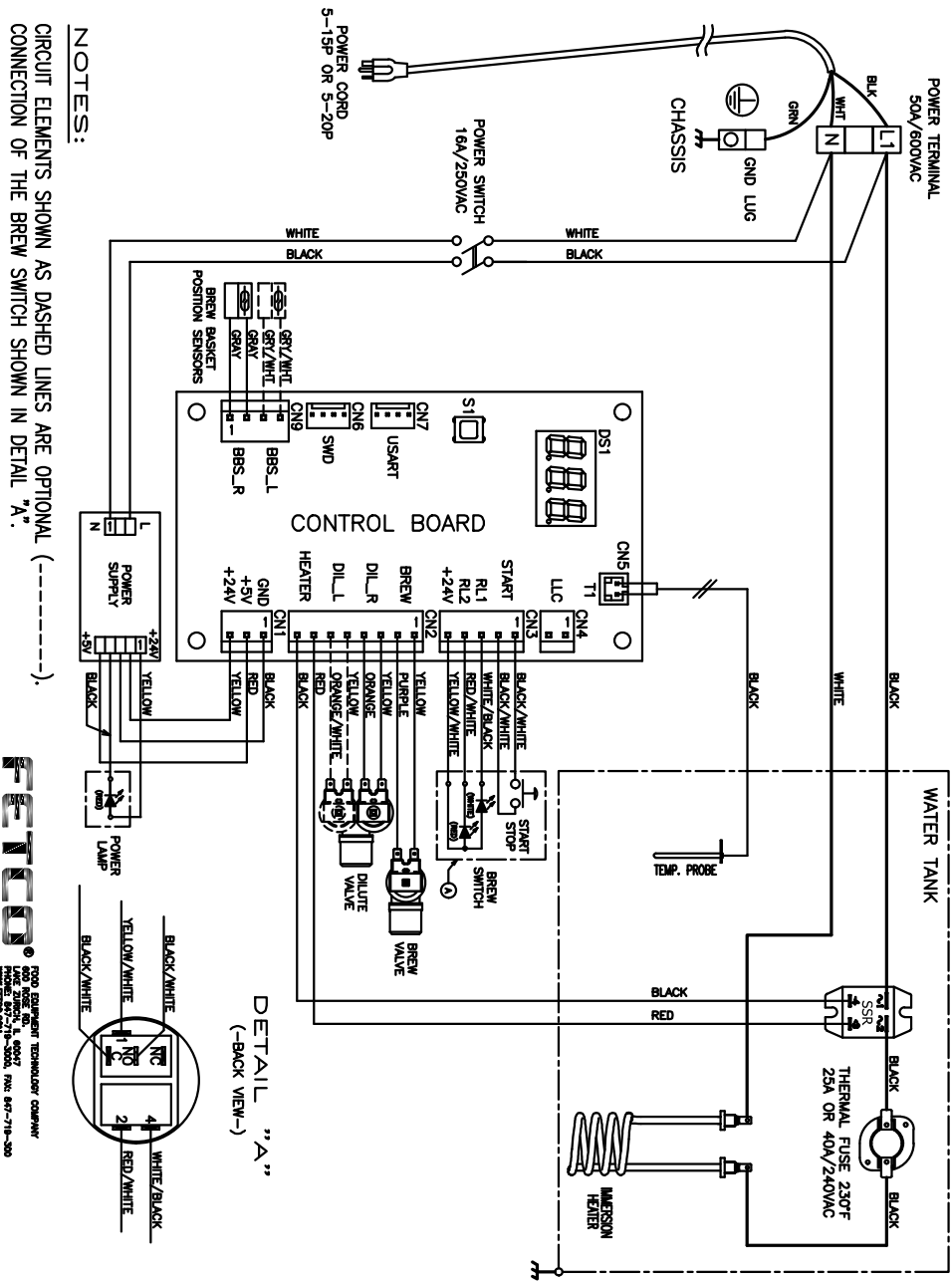

NOTES:

CIRCUIT ELEMENTS SHOWN AS DASHED LINES ARE OPTIONAL CONNECTION OF THE BREW SWITCH SHOWN IN DETAIL "A".

DWG. NAME: WIRING DIAGRAM, TBS-V, (L1, N + GND), 120VAC HEATER, UL. 1401.00163.00

©2008 EQUIPMENT TECHNOLOGY COMPANY
 800 WEST 10TH AVENUE, SUITE 100
 DENVER, CO 80202, USA
 PHONE: 877-716-3222 FAX: 877-716-3000
 WWW.ETCO.COM

Optional tea dispenser instructions and cleaning

FETCO ITD-2135 3 gallon Ice Tea Dispenser

Product D-064

Instructions for use

- Remove dispenser cover before brewing, replace cover after brew is complete
- To prevent overflow, make sure the dispenser is completely empty before brewing into it.
- Discard old tea often during the day and make a fresh batch
- Never keep tea overnight in this or any dispenser.
- Use only the handles to lift or carry the dispenser

Cleaning Instructions

Do not use bleach or cleaners containing chlorides.
Use any commercial beverage urn cleaner to clean the inside of the dispenser.
 Follow the cleaner manufacturer's instructions.
 Thoroughly rinse the dispenser after cleaning.
Remove faucet body from shank by unscrewing plastic wing nut as shown
Disassemble upper assembly and remove the faucet upper assembly as shown
 Inspect the seat cup for wear. Clean or replace if necessary.
 Wash plastic parts with cleaning brush and dish detergent. Avoid abrasives

To sanitize the dispenser before filling, brew a batch of water only (no tea) into the dispenser allow it to rest for 10 minutes-and drain. Repeat daily, or as needed.

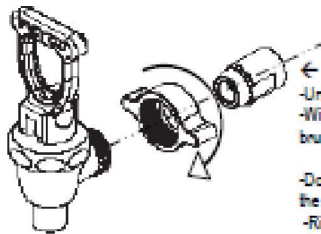

← Faucet Shank
 -Unscrew and remove faucet body.
 -With cleaner or hot soapy water—use brush to clean faucet shank.
 -Do not allow sharp bush tip to contact the soft seat cup.
 -Rinse and Dry



-Unscrew and remove
 -Clean faucet body and upper assembly by soaking in commercial dispenser cleaner or hot soapy water.
 -Rinse and Dry

We recommend Urnex Tabz™ Tea Clean for use on FETCO® tea brewing equipment

- Specifically formulated for the removal of tea stains from tea brewing equipment.
- Daily cleaning of loaded Tea Dispensers ensures fresh tasting iced tea and properly maintained equipment.
- Cleans brew basket and serving vessel in one simple step
- Sanitizes all types of tea ware for bright and sparkling flavor of brewed tea

INSTRUCTIONS FOR DAILY USE:

Simple directions to use Urnex Tabz™



- 1 Drain all product from dispenser
- 2 Place four tablets in center of brew basket
- 3 Run brew cycle into server and hold.
- 4 Discard solution and remove any residue.
- 5 Rinse all parts with clean water. REPEAT

